



# **SURE STAR COMPUTER CO., LTD**

NO.2-1,DAAN ROAD, SHULIN .DIST., NEW TAIPEI CITY 238 , TAIWAN.

E-mail: info@surestar.com.tw

Tel: +886 2 2682 2505

http://www.surestar.com.tw

Fax: +886 2 2682 2515

## **Model Name:SS-2U70EL**

**(700W power supply for 2U Single Efficiency  $\geq$  86%)**

**High  
Efficiency**

**Low Noise**



### **1. Specification**

1.1.AC Input Voltage Range: 100VAC ~ 240VAC,  $\pm$ 10%, 47 to 63 Hz.

1.2.INPUT CURRENT:10 A ( RMS ) FOR 115VAC /5.0 A ( RMS ) FOR 230VAC.

1.3. Input Power Factor: The minimum power factor at full load shall be  
0.98/115V 60 Hz and 0.95/230V 50 Hz.

1.4. Inrush current: 40A MAX. FOR 115 VAC / 60A MAX. FOR 230 VAC.

1.5.DC Output: 700W maximum

	Output-1	Output-2	Output-3	Output-4	Output-5
Output Voltage	+5V DC	+12V DC	-12V DC	+3.3V DC	+5VSB
Output Current(Max)	25A	56A	0.8A	25A	3.5A
Output Current(Min.)	0.5A	2A	0A	0.5A	0.1A
Ripple/Noise Max.(P-P):	60mv	120mv	120mv	60mv	60mV
Line Regulation:	$\pm$ 1%	$\pm$ 1%	$\pm$ 1%	$\pm$ 1%	$\pm$ 1%
Load Regulation:	$\pm$ 5%	$\pm$ 5%	$\pm$ 5%	$\pm$ 5%	$\pm$ 5%

#### **Note:**

1. Noise Test – Noise bandwidth is from DC to 20 MHz.

2. Ripple frequencies greater than 1MHz shall be attenuated by the measurement System.

3.Add 0.1uF/10uF capacitor at output connector terminals for ripple and noise measurements.

4.The combined total power from 5V & 3.3V shall not exceed 180W.

### 1.6 PS-ON

#### Remote On/Off Control:

When PS-ON is pulled to TTL Low, the DC output is to be enabled.

When PS-OFF is pulled to TTL high, the DC output is to be disabled.

### 1.7 PW-OK

PW-OK is power good signal and should be asserted high by the power supply to indicate that +5VDC and +3.3VDC output are above the under voltage thresholds of the power supply TTL. compatible signal out with 100ms to 500ms.

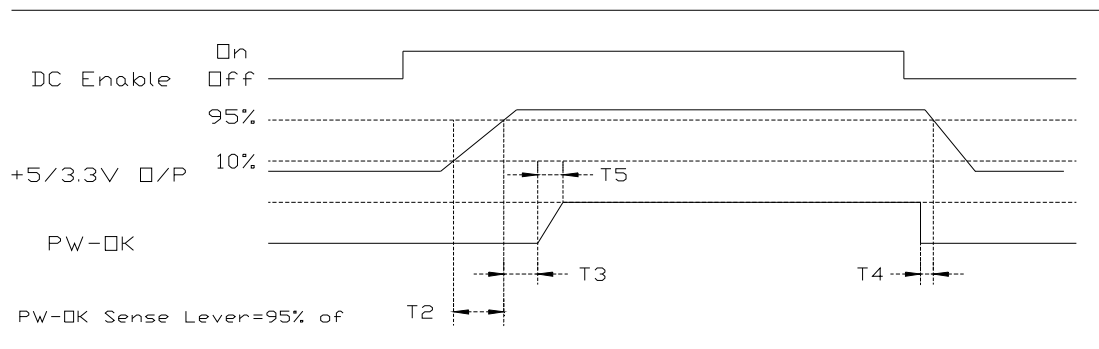

### Timing of PS-ON, PW-OK, and Germane Voltage Rails

Although there is no requirement to meet specific timing parameters, The following signal timings are recommended:

$$2\text{ms} \leq T2 \leq 200\text{ms}$$

$$100\text{ms} \leq T3 \leq 500\text{ms}$$

$$T4 > 1\text{ms}$$

$$T5 \leq 10\text{ms}$$

1.8 Efficiency: TYPICAL >86% AT 115VAC , FULL LOAD.

1.9.Hold-Up Time: 16ms at maximum load & normal input voltage.

## 2. PROTECTIONS

### 2.1 OVER-VOLTAGE PROTECTION

OUTPUT	Min	Max
+3.3V	3.7V	4.1V
+5V	5.7V	6.5V
+12V	13.1V	14.5V

### 2.2 SHORT CIRCUIT PROTECTION

A short circuit placed between the DC Return and the output shall cause No damage and the power supply shall shutdown.

### 2.3 OVER POWER PROTECTION

The power supply shall shut down when output power exceeds 110% to 160% of full load and require a power on cycle be performed by the operate

## 3. ENVIRONMENT TEMPERATURE

3.1 Operation Temperature: 0°C to 45°C

3.2 Cooling: By forced air

3.3 Storage Temperature:-20°C to 70°C

3.4 Humidity: 5 to 90% non-condensing.

## 4. Mean Time Between Failure(MTBF)

Using MIL - HDBK -217F the calculated MTBF=100,000 hours at 25°C 75% loading.

## 5. SAFETY:

UL 60950-1, 2<sup>ND</sup> Edition, CSA C 22.2 No. 60950-1-07, 2<sup>nd</sup> Edition, 2007-03

TUV EN60950-1: 2006+A11+A1+A12

CB IEC60950-1: 2005

BSMI CNS14336-1, CNS13438

CCC 4943.1-2011

## 6. EMI NOISE FILTER:

EN55022:2006+A1:2007, EN55024:1998+A1:2001+A2:2003

EN61000-3-2: 2006+A2:2009 EN61000-.3-3: 2008, IEC61000-4-2,-3,-4,-5,-6,-8,-11

## 7. DIMENSION

L 225 x W 100 x H 70 mm

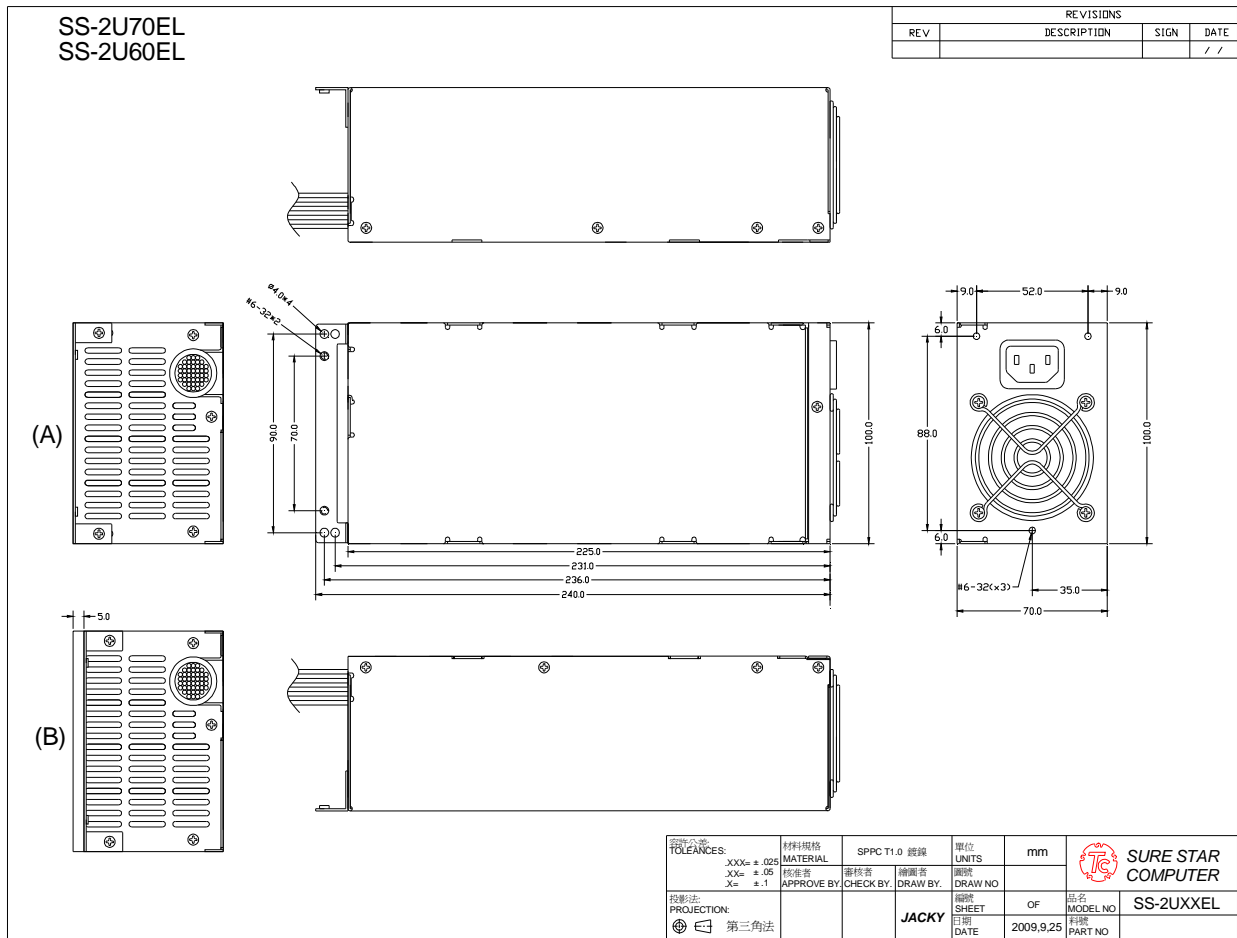

## 8. PINOUTS OF CONNECTORS

- ATX or EPS (20+4)Pin x 1 ,
- M8P +12V Power Connector x 1 ,
- M4P +12V Power Connector x 1 ,
- H.D.D. x 12 ,
- Floppy x 1
- SATA x 2.

Below cable length start from Outer cage:

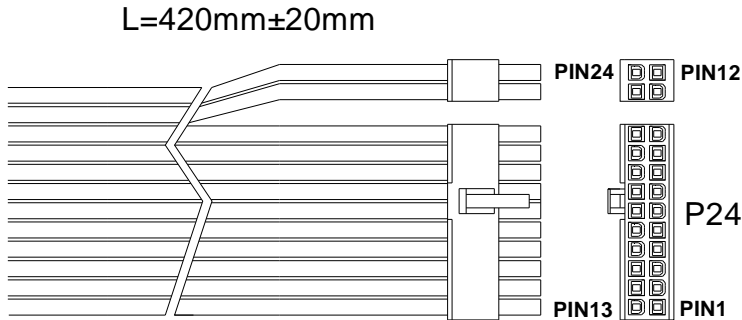

24Pins(EPS12V) Connector HOUSING: MOLEX 39-01-2240 or equivalent TERMINAL: MOLEX 39-00-0039 or equivalent						
Housing	Pin No.	WIRE COLOR	LENGTH	Pin No.	WIRE COLOR	LENGTH
P24	1	ORANGE(+3.3V)	420mm/18AWG	13	ORANGE(+3.3V) ORANGE(+3.3Vs)	420mm/18AWG 420mm/22AWG
	2	ORANGE(+3.3V)	420mm/18AWG	14	BLUE(-12V)	420mm/18AWG
	3	BLACK(GND)	420mm/18AWG	15	BLACK(GND)	420mm/18AWG
	4	RED(+5V)	420mm/18AWG	16	GREEN(PS-ON)	420mm/20AWG
	5	BLACK(GND)	420mm/18AWG	17	BLACK(GND)	420mm/18AWG
	6	RED(+5V)	420mm/18AWG	18	BLACK(GND)	420mm/18AWG
	7	BLACK(GND)	420mm/18AWG	19	BLACK(GND)	420mm/18AWG
	8	GRAY(PG)	420mm/20AWG	20	NC	
	9	PURPLE(+5VSB)	420mm/18AWG	21	RED(+5V)	420mm/18AWG
	10	YELLOW(+12V)	420mm/18AWG	22	RED(+5V)	420mm/18AWG
	11	YELLOW(+12V)	420mm/18AWG	23	RED(+5V)	420mm/18AWG
	12	ORANGE(+3.3V)	420mm/18AWG	24	BLACK(GND)	420mm/18AWG

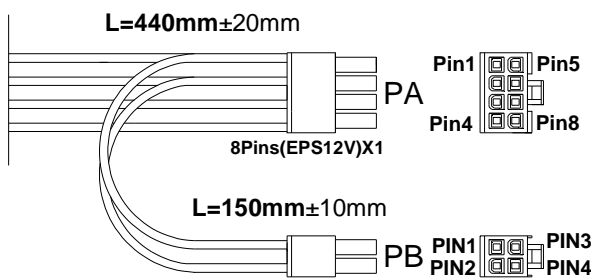

Housing	Pin	WIRE COLOR	LENGTH	Pin	WIRE COLOR	LENGTH
PA	1	Black/Black	440mm/18AWG	5	Yellow/Yellow	440mm/18AWG
	2	Black/Black		6	Yellow/Yellow	
	3	Black		7	Yellow	
	4	Black		8	Yellow	
PB	1	Black	150mm/18AWG	3	Yellow	150mm/18AWG
	2	Black	150mm/18AWG	4	Yellow	150mm/18AWG

Connector HOUSING: MOLEX 39-01-0280 or equivalent  
Connector HOUSING: MOLEX 39-01-0240 or equivalent

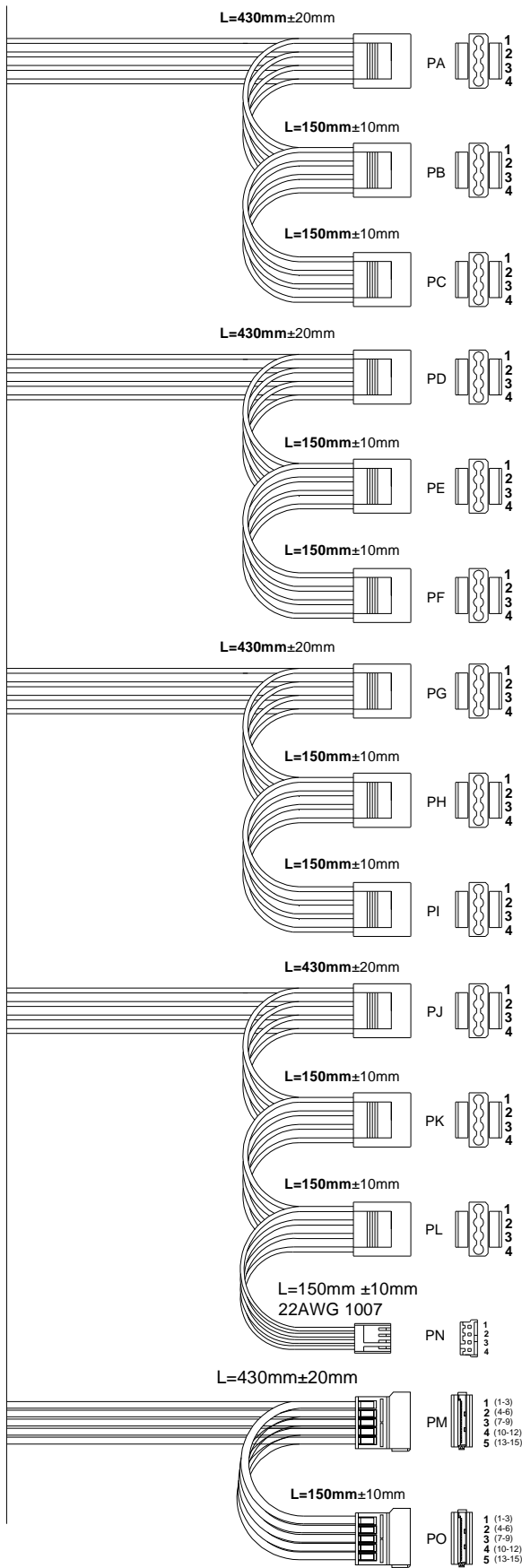

Housing	Pin No.	WIRE COLOR	LENGTH	Pin No.	WIRE COLOR	LENGTH
PA	1	Yellow / Yellow	430mm/18AWG	3	Black / Black	430mm/18AWG
	2	Black / Black	430mm/18AWG	4	Red / Red	430mm/18AWG
PB	1	Yellow / Yellow	150mm/18AWG	3	Black / Black	150mm/18AWG
	2	Black / Black	150mm/18AWG	4	Red / Red	150mm/18AWG
PC	1	Yellow	150mm/18AWG	3	Black	150mm/18AWG
	2	Black	150mm/18AWG	4	Red	150mm/18AWG

Connector Housing: H.D.D. for easy plug

Housing	Pin No.	WIRE COLOR	LENGTH	Pin No.	WIRE COLOR	LENGTH
PD	1	Yellow / Yellow	430mm/18AWG	3	Black / Black	430mm/18AWG
	2	Black / Black	430mm/18AWG	4	Red / Red	430mm/18AWG
PE	1	Yellow / Yellow	150mm/18AWG	3	Black / Black	150mm/18AWG
	2	Black / Black	150mm/18AWG	4	Red / Red	150mm/18AWG
PF	1	Yellow	150mm/18AWG	3	Black	150mm/18AWG
	2	Black	150mm/18AWG	4	Red	150mm/18AWG

Connector Housing: H.D.D. for easy plug

Housing	Pin No.	WIRE COLOR	LENGTH	Pin No.	WIRE COLOR	LENGTH
PG	1	Yellow / Yellow	430mm/18AWG	3	Black / Black	430mm/18AWG
	2	Black / Black	430mm/18AWG	4	Red / Red	430mm/18AWG
PH	1	Yellow / Yellow	150mm/18AWG	3	Black / Black	150mm/18AWG
	2	Black / Black	150mm/18AWG	4	Red / Red	150mm/18AWG
PI	1	Yellow	150mm/18AWG	3	Black	150mm/18AWG
	2	Black	150mm/18AWG	4	Red	150mm/18AWG

Connector Housing: H.D.D. for easy plug

Housing	Pin No.	WIRE COLOR	LENGTH	Pin No.	WIRE COLOR	LENGTH
PJ	1	Yellow / Yellow	430mm/18AWG	3	Black / Black	430mm/18AWG
	2	Black / Black	430mm/18AWG	4	Red / Red	430mm/18AWG
PK	1	Yellow / Yellow	150mm/18AWG	3	Black / Black	150mm/18AWG
	2	Black / Black	150mm/18AWG	4	Red / Red	150mm/18AWG
PL	1	Yellow / Yellow	150mm/18AWG	3	Black / Black	150mm/18AWG
	2	Black / Black	150mm/18AWG	4	Red / Red	150mm/18AWG
PN	1	Yellow	150mm/22AWG	3	Black	150mm/22AWG
	2	Black	150mm/22AWG	4	Red	150mm/22AWG

Connector Housing: H.D.D. for easy plug

Connector HOUSING: AMP 171822-4 or equivalent

Housing	Pin No.	WIRE COLOR	LENGTH
PM	1	Orange / Orange	430mm/18AWG
	2	Black / Black	430mm/18AWG
	3	Red / Red	430mm/18AWG
	4	Black / Black	430mm/18AWG
	5	Yellow / Yellow	430mm/18AWG
PO	1	Orange	150mm/18AWG
	2	Black	150mm/18AWG
	3	Red	150mm/18AWG
	4	Black	150mm/18AWG
	5	Yellow	150mm/18AWG

HOUSING: MOLEX 675820000 or equivalent

TERMINAL: MOLEX 675810000 or equivalent

**Note: Specification and wiring diagram subject to change without notice.**

Dec. 25, 2012